

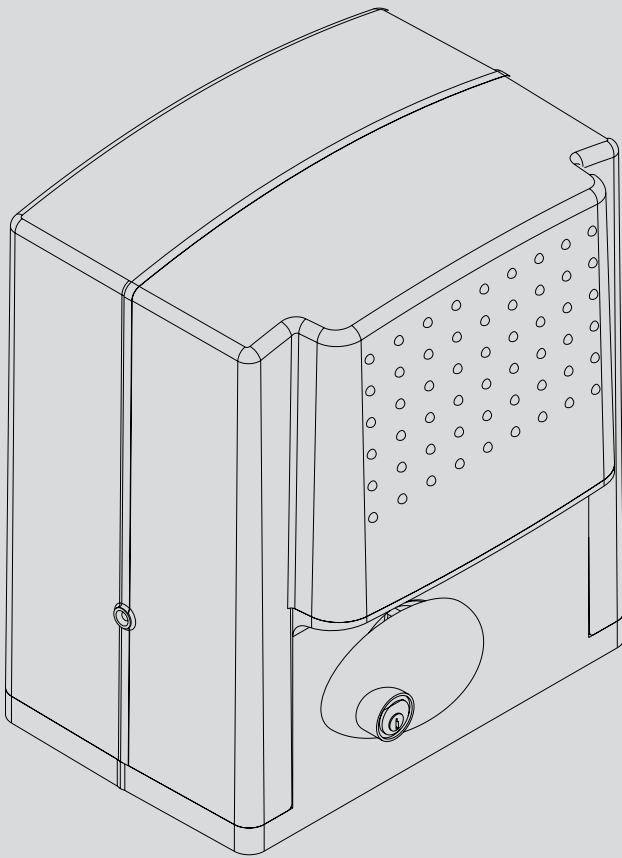

D811692.00100_01.07-01-10

ATTUATORE PER CANCELLI SCORREVOLI A CREMAGLIERA
 ACTUATOR FOR RACK SLIDING GATES
 ACTIONNEUR POUR PORTAILS COULISSANTS A CREMAILLIERE
 ANTRIEB FÜR ZAHNSTANGEN-SCHIEBETORE
 SERVOMOTOR PARA CANCELAS CORREDERAS DE CREMALLERA
 ACTUATOR VOOR SCHUIFHEKKEN MET TANDHEUGEL



ARES

ISTRUZIONI D'USO E DI INSTALLAZIONE
 INSTALLATION AND USER'S MANUAL
 INSTRUCTIONS D'UTILISATION ET D'INSTALLATION
 INSTALLATIONS-UND GEBRAUCHSANLEITUNG
 INSTRUCCIONES DE USO Y DE INSTALACION
 INSTALLATIEVOORSCHRIFTEN

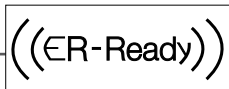
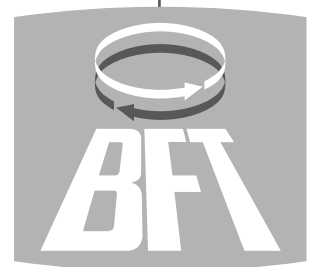

AZIENDA CON SISTEMA DI GESTIONE
 INTEGRATO CERTIFICATO DA DNV
 = UNI EN ISO 9001:2000 =
 UNI EN ISO 14001:2004

Attenzione! Leggere attentamente le "Avvertenze" all'interno! **Caution!** Read "Warnings" inside carefully! **Attention!** Veuillez lire attentivement les Avertissements qui se trouvent à l'intérieur!
Achtung! Bitte lesen Sie aufmerksam die „Hinweise“ im Inneren! **¡Atención!** Leer atentamente las "Advertencias" en el interior! **Let op!** Lees de "Waarschuwingen" aan de binnenkant zorgvuldig!

INSTALLAZIONE VELOCE-QUICK INSTALLATION-INSTALLATION RAPIDE SCHNELLINSTALLATION-INSTALACIÓN RÁPIDA - SNELLE INSTALLATIE

ITALIANO

ENGLISH

FRANÇAIS

DEUTSCH

ESPAÑOL

NEDERLANDS

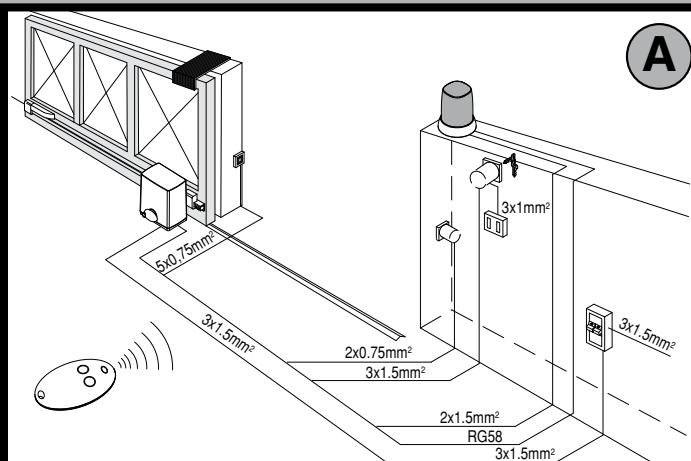

**PREDISPOSIZIONE TUBI, TUBE ARRANGEMENT,
PRÉDISPOSITION DES TUYAUX, VORBEREITUNG DER LEITUNGEN,
DISPOSICIÓN DE TUBOS, VOORBEREIDING LEIDINGEN.**

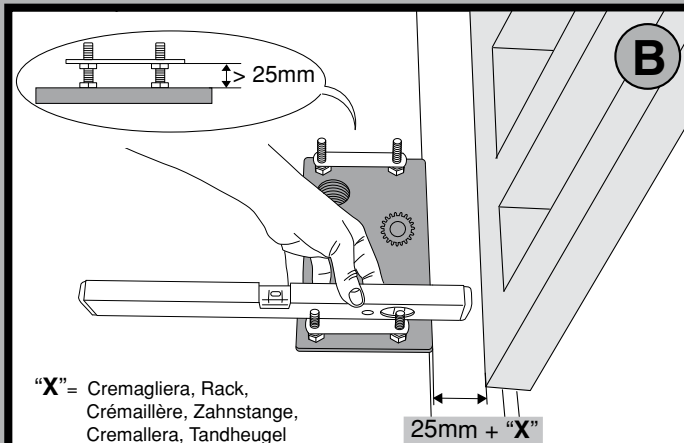

**Predisposizione fissaggio motore, Preparation for motor mounting,
Aménagement fixation moteur, Vorbereitung Motorbefestigung,
Disposición fijación del motor, Voorbereiding bevestiging motor.**

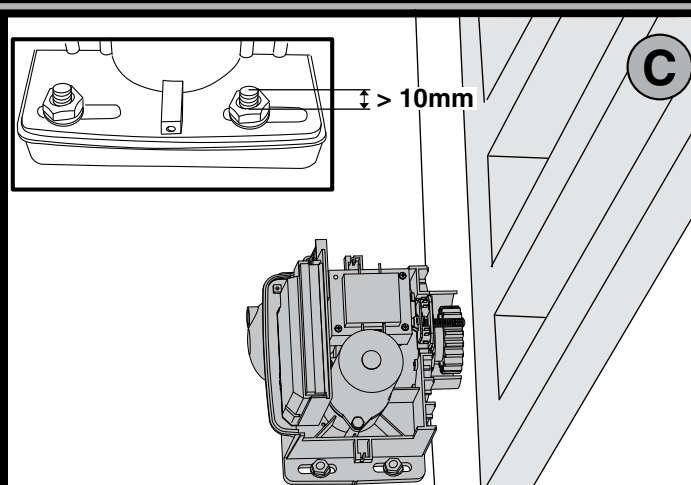

**Montaggio motore, Mounting the motor, Montage moteur,
Montage Motor, Montaje del motor, Montage motor.**

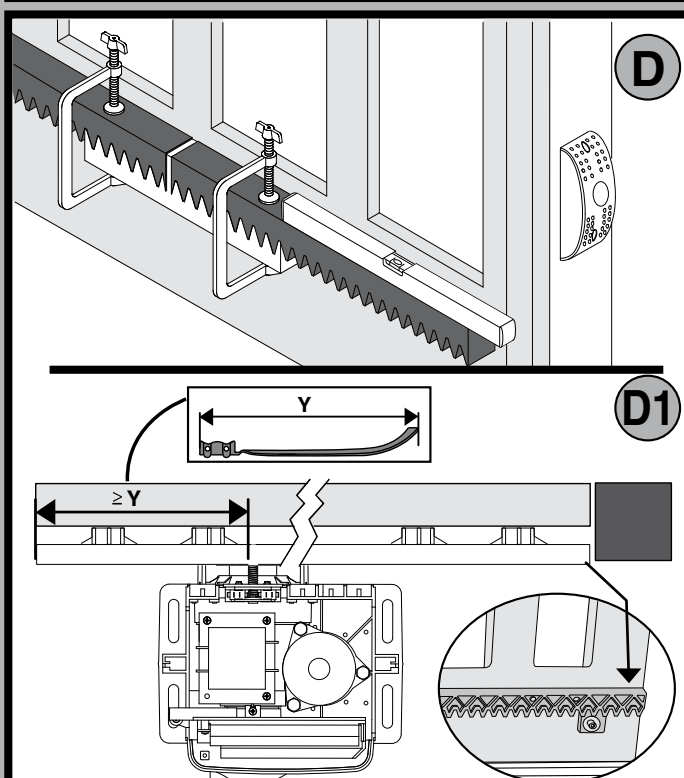

**Montaggio accessori trasmissione, Mounting drive accessories,
Montage accessoires transmission, Montage Antriebszubehör,
Montaje de accesorios transmisión, Montage accessoires overbrenging.**

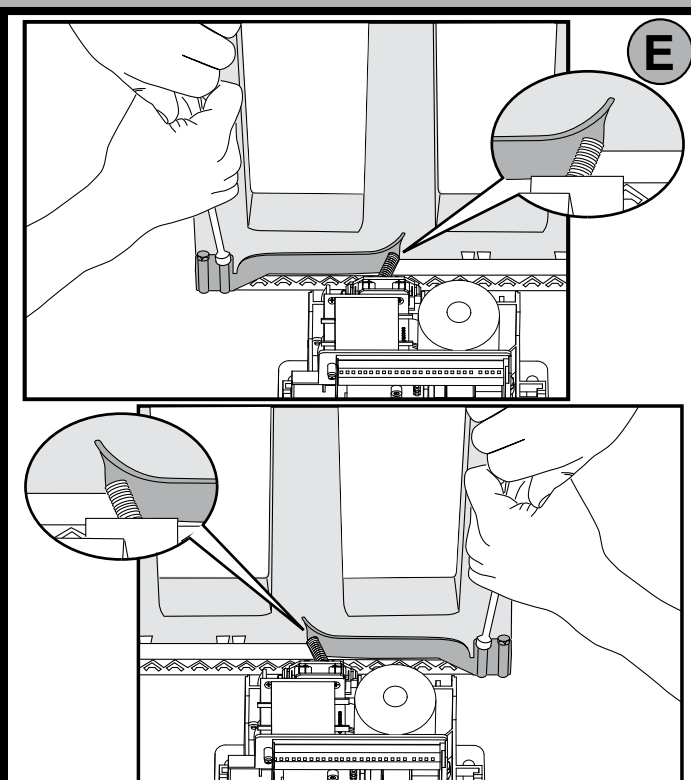

**Fissaggio staffe finecorsa (dx e sx), Fastening limit switch brackets (RH/LH),
Fixation étriers fin de course (drt et gch), Befestigung Bügel Anschläge (rechts und links),
Fijación abrazaderas final de carrera (der. e izq.),
Bevestiging stangen aanslag (rechts en links).**

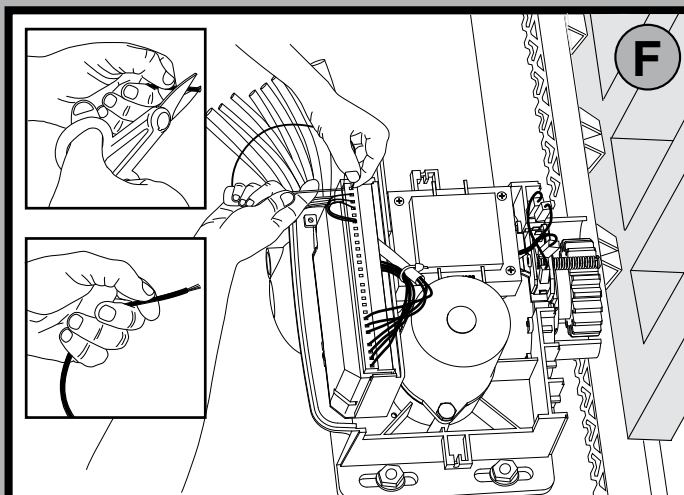

**Collegamento morsetti, Terminal board wiring,
Connexion plaque à bornes, Anschluss Klemmleiste,
Conexión tablero de bornes, Aansluiting aansluitkast.**

G

Grigio-Grey-Gris-Grau-Gris-Grijs
Grigio-Grey-Gris-Grau-Gris-Grijs

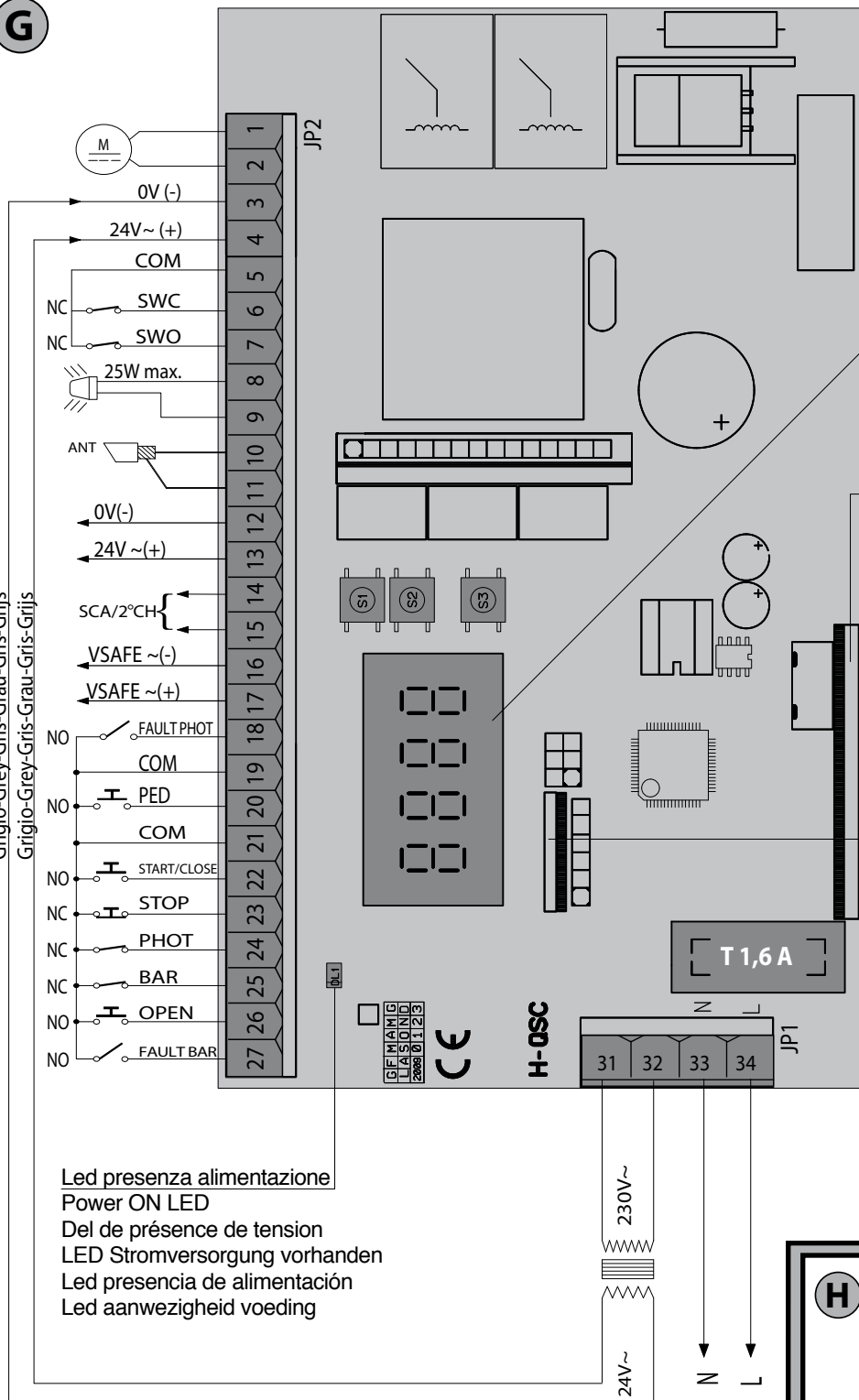

Display + tasti programmazione
Display + programming keys
Afficheur + touches programmation
Display + Programmierungstasten
Pantalla + botones programación
Display + programmeringstoetsen

Connettore scheda opzionale
Optional board connector
Connecteur carte facultative
Steckverbinder Zusatzkarte
Conector de la tarjeta opcional
Connector optionele kaart

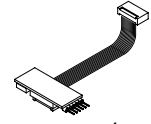

Connettore programmatore palmare,
Palmtop programmer connector,
Connecteur programmeur de poche,
Steckverbinder Palmtop-Programmierer,
Conector del programador de bolsillo,
Connector programmeerbare palmtop

Led presenza alimentazione
Power ON LED
Del de présence de tension
LED Stromversorgung vorhanden
Led presencia de alimentación
Led aanwezigheid voeding

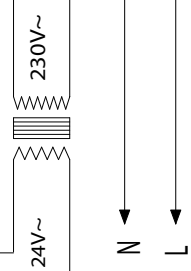

H Collegamento di 1 coppia fotocellule non verificate
Connection of 1 pair of non-tested photocells
Connexion 1 paire photocellules non vérifiées
Anschluss von einem Paar nicht überprüften Fotozellen
Conexión de 1 par fotocélulas no comprobadas
Aansluiting van 1 paar fotocellen anders dan "trusted device"

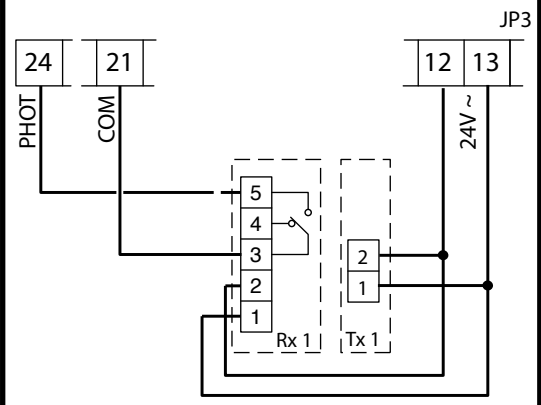

LOGICA test fotocellule OFF / Photocell test LOGIC OFF
LOGIQUE essai photocellules Désactivée /
LOGIK Test Fotozellen OFF
LÓGICA prueba fotocélulas OFF / LOGICA test fotocellen OFF

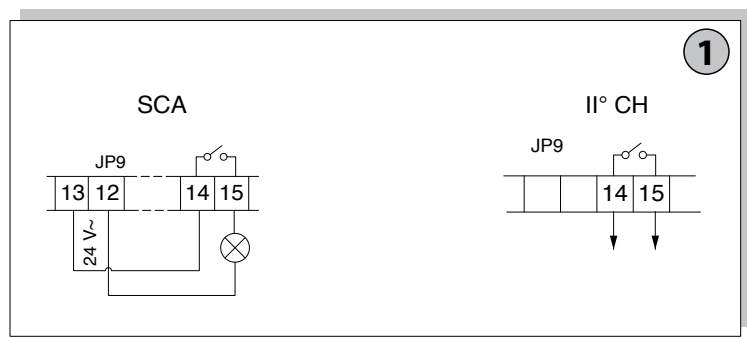

SIMPLIFIED MENU

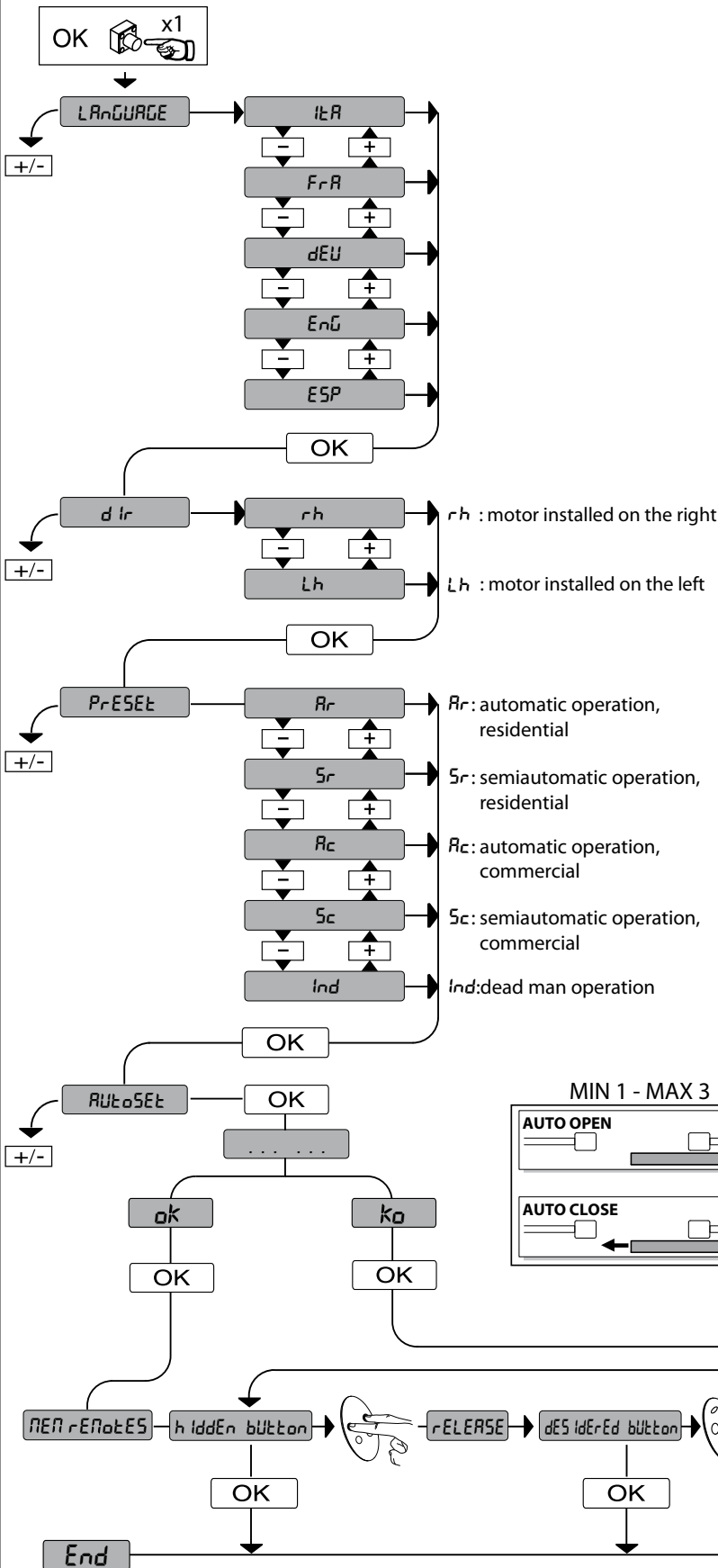

PRESET	DEFAULT	Rr	Sr	Rc	Sc	ind
PARAMETERS						
Automatic Closing Time	40	40	40	40	40	40
Slow-down speed	15	15	15	15	15	15
Opening motor torque	75	75	75	75	75	75
Closing motor torque	75	75	75	75	75	75
Speed during opening	99	99	99	99	99	99
Speed during closing	99	99	99	99	99	99
Partial opening	40	40	40	40	40	40
Zone	0	0	0	0	0	0
Slow-down distance	0	0	0	0	0	0
Opening deceleration space	10	10	10	10	10	10
Closing deceleration space	10	10	10	10	10	10
LOGIC						
Automatic Closing Time	OFF	ON	OFF	ON	OFF	OFF
Block Pulses	OFF	OFF	OFF	ON	ON	OFF
Impulse lock TCA	OFF	OFF	OFF	OFF	OFF	OFF
3 step	OFF	ON	OFF	ON	OFF	OFF
Pre-alarm	OFF	OFF	OFF	ON	ON	OFF
Deadman	OFF	OFF	OFF	OFF	OFF	ON
Photocells during opening	OFF	ON	ON	ON	ON	OFF
Photocell test	OFF	OFF	OFF	OFF	OFF	OFF
Safety edge testing	OFF	OFF	OFF	OFF	OFF	OFF
Master/Slave	OFF	OFF	OFF	OFF	OFF	OFF
Fixed code	OFF	OFF	OFF	OFF	OFF	OFF
Remote control programming	ON	ON	ON	ON	ON	ON
Gate open light or 2nd radio channel	OFF	OFF	OFF	OFF	OFF	OFF
START - CLOSE setting	OFF	OFF	OFF	OFF	OFF	OFF
Reversing motion	-	-	-	-	-	-
ICE	OFF	OFF	OFF	OFF	OFF	OFF

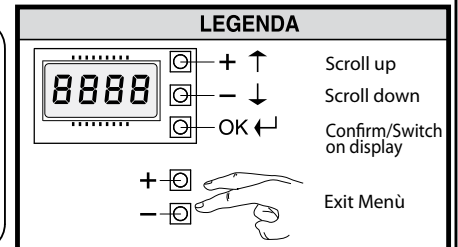
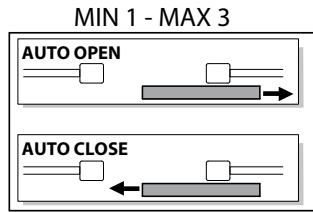

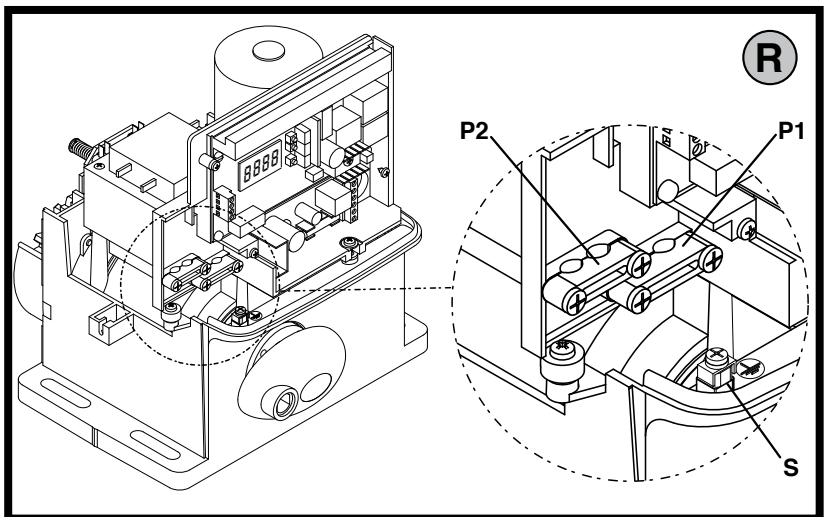
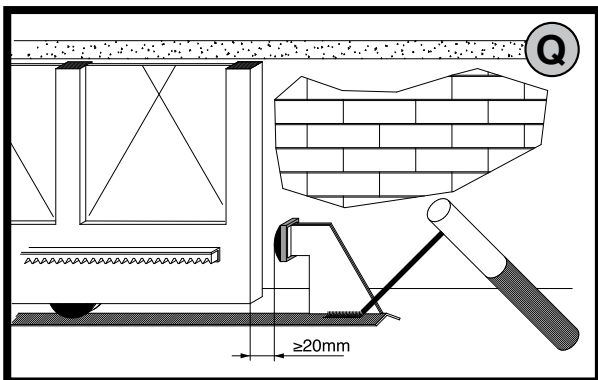
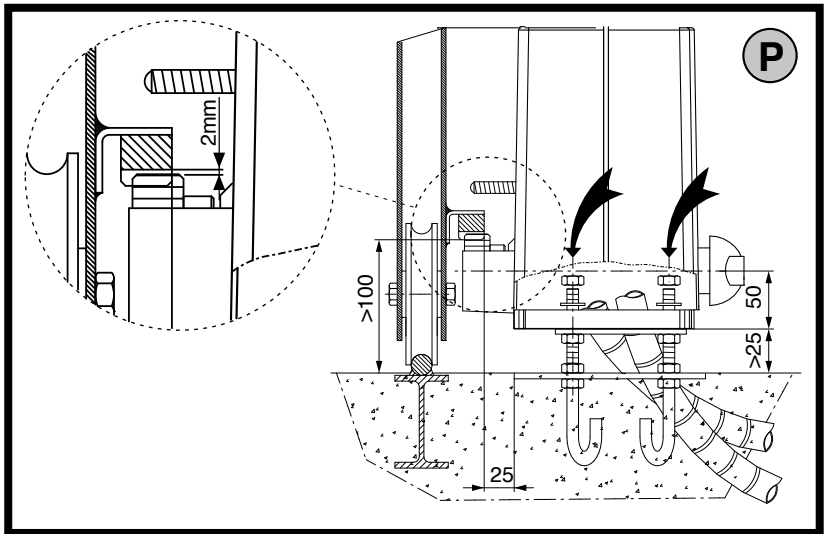
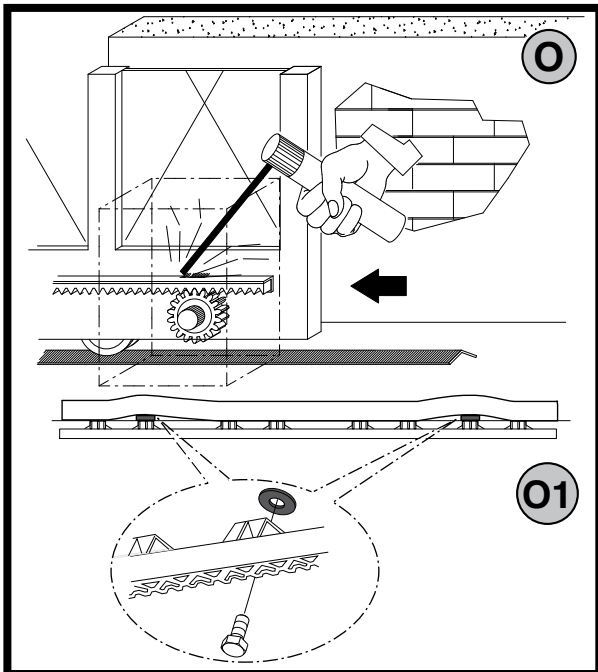
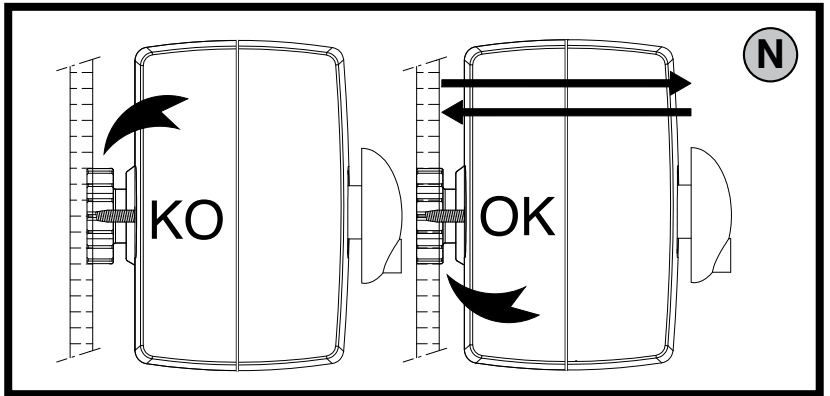
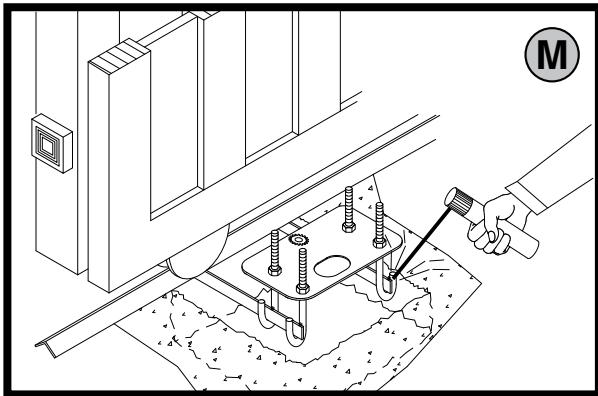
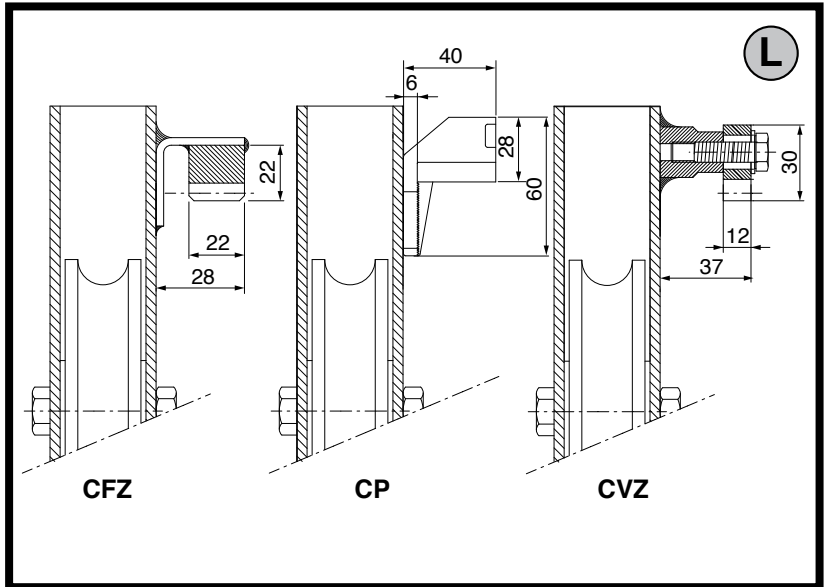
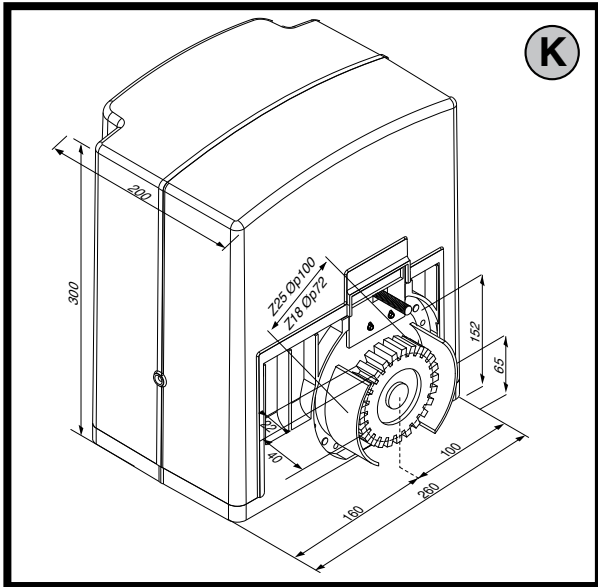

S

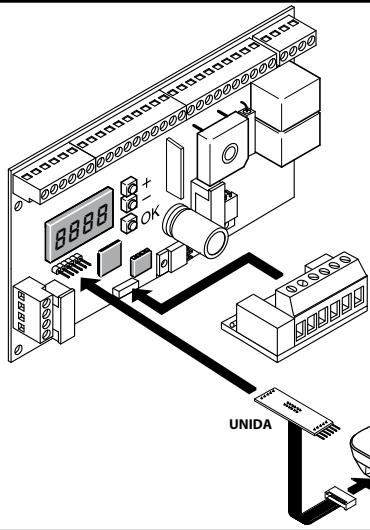

SCHEDA DI ESPANSIONE
EXPANSION BOARD
CARTE EXPANSION
ERWEITERUNGSKARTE
TARJETA DE EXPANSIÓN
UITBREIDINGSKAART

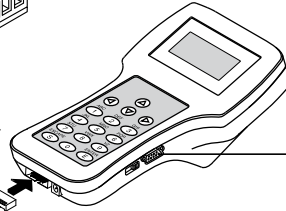

Programmatore palmare universale
Universal palmtop programmer
Programmeur de poche universel
Universellen Palmtop-Programmierer
Programador de bolsillo universal
Programmeerbare Universele Palmtop

Connessione seriale per ante contrapposte, Serial connection for opposite leaves, Connexion série pour vantaux opposés, Serieller Anschluss für einander entgegengesetzte Torflügel, Conexión serial para hojas contrapuestas, Serielle verbinding voor tegenovergestelde vleugels.

T

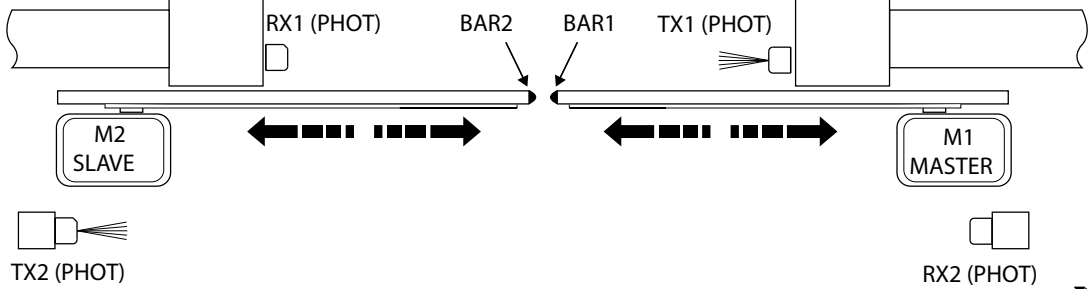

ZonE=128
MASTER=OFF

ZonE=128
MASTER=ON

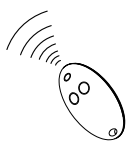
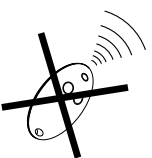
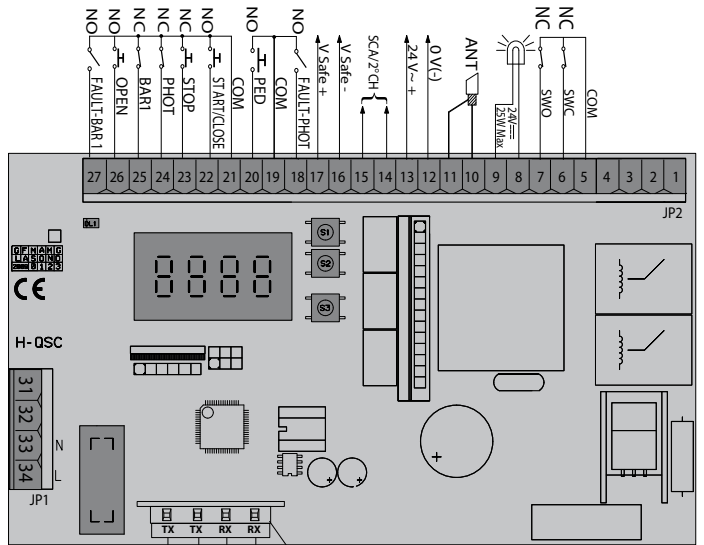
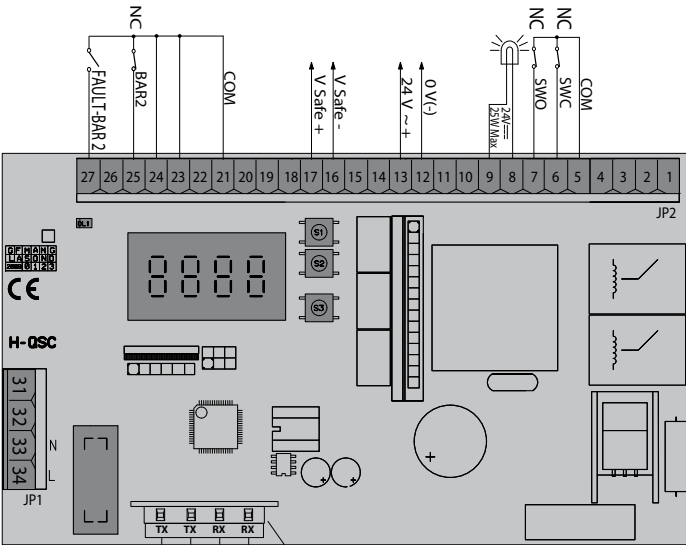

Connessione Seriale Mediante Scheda SCS1, Serial Connection Via SCS1 Card, Connexion Série À Travers La Carte SCS1, Serielle Verbindung Mit Karte SCS1, Conexión Serial Mediante Tarjeta SCS1, Serielle Verbindung Mittels Kaart SCS1.

U

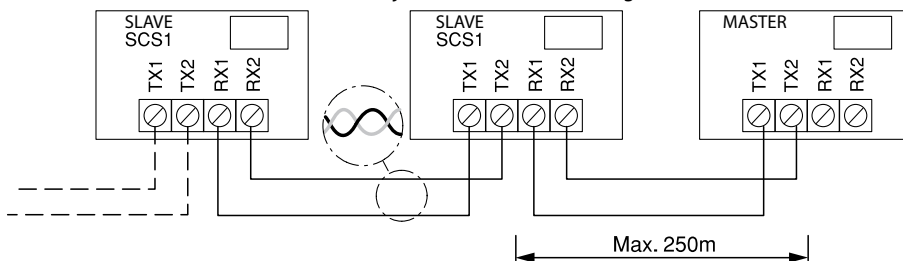

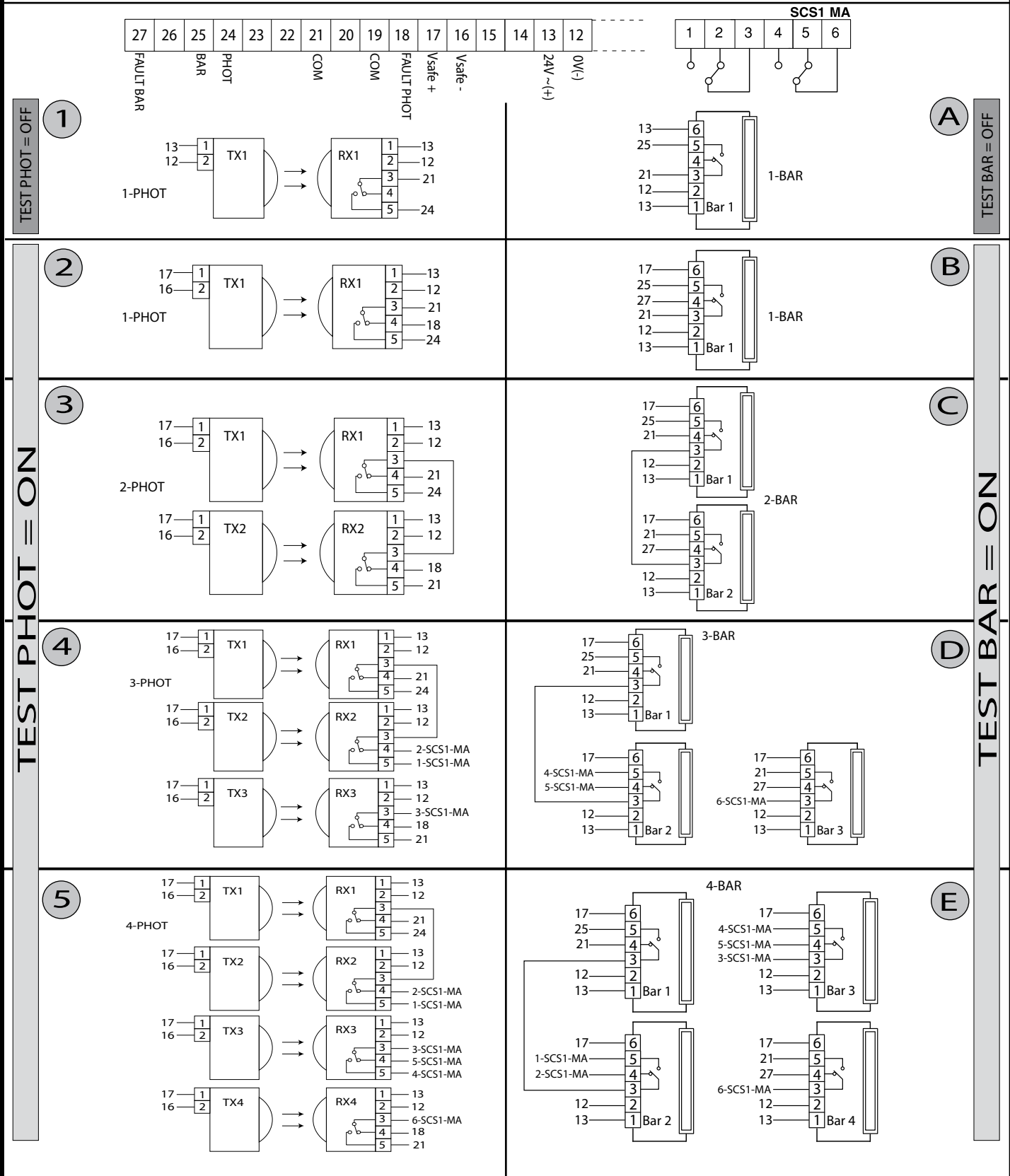

Numero massimo dispositivi collegabili, Maximum number of devices that can be connected, Nombre maximum de dispositifs pouvant être connectés, Max. Anzahl der anschließbaren Geräte, Número máximo dispositivos que se pueden conectar, Maximum aantal aansluitbare inrichtingen.

TEST Bar=on / TEST Phot=on		
FOTOCPELLULE PHOTOCELLULES	FOTOCÉLULAS PHOTOCELLS	FOTOCZELLEN FOTOCZELLEN
3		
5		
COSTE LINTEAUX	CANTOS SAFETY EDGES	LEISTEN RANDEN
E		
C		

ACCESS TO MENUS Fig. 1

LEGENDA

+ ↑ Scroll up
 - ↓ Scroll down
 OK ↵ Confirm/Switch on display
 + Exit Menu
 - Exit Menu

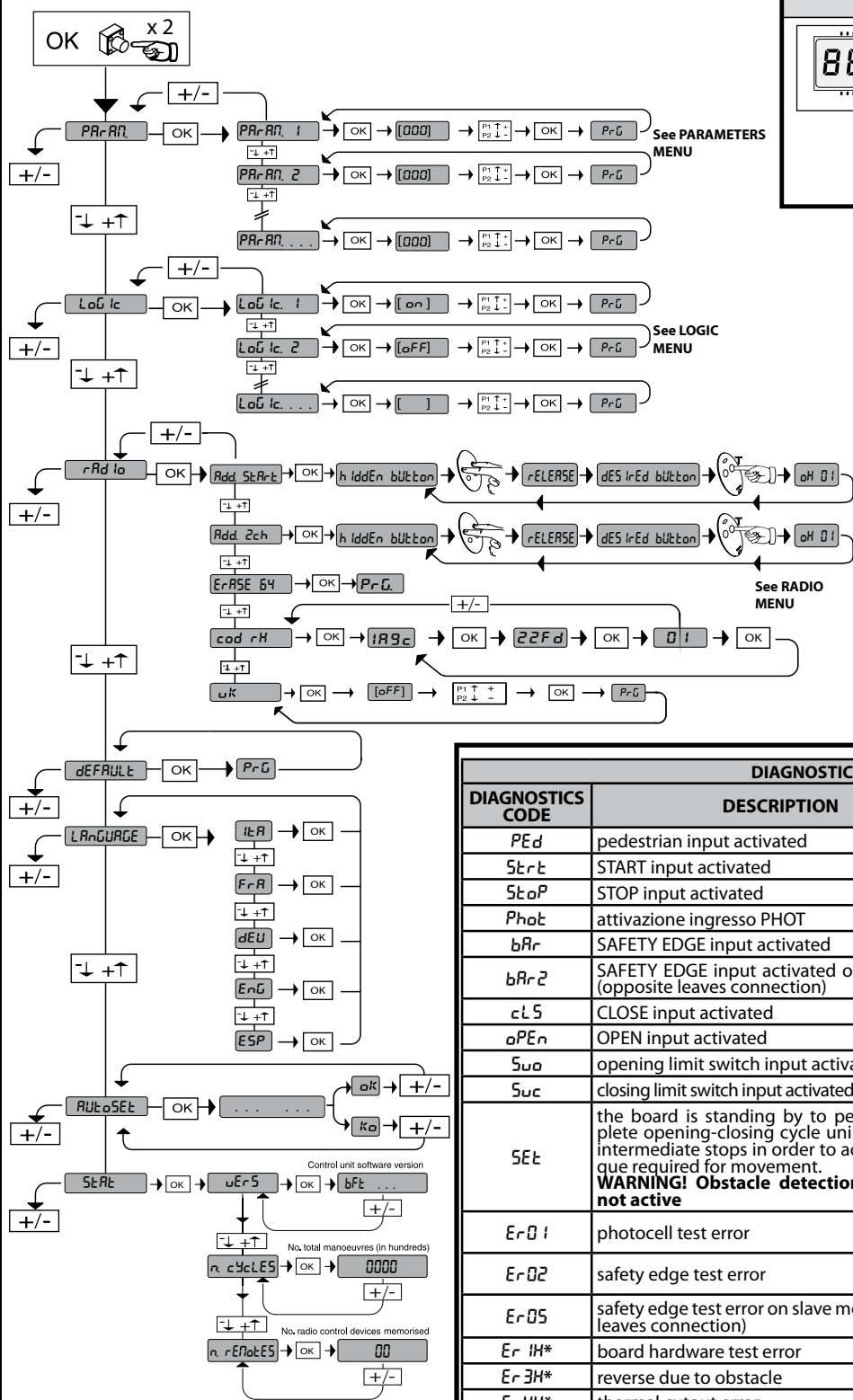

DIAGNOSTICS and WARNINGS		
DIAGNOSTICS CODE	DESCRIPTION	NOTES
PEd	pedestrian input activated	
StAr	START input activated	
StoP	STOP input activated	
PhoE	attivazione ingresso PHOT	
bAr	SAFETY EDGE input activated	
bAr-2	SAFETY EDGE input activated on slave motor (opposite leaves connection)	
cLS	CLOSE input activated	
oPEn	OPEN input activated	
Suo	opening limit switch input activated	
Suc	closing limit switch input activated	
SEt	the board is standing by to perform a complete opening-closing cycle uninterrupted by intermediate stops in order to acquire the torque required for movement. WARNING! Obstacle detection function is not active	
Er-01	photocell test error	check photocell connection and/or logic settings
Er-02	safety edge test error	check safety edge connection and/or logic settings
Er-05	safety edge test error on slave motor (opposite leaves connection)	check safety edge connection and/or parameter/logic settings
Er-1H*	board hardware test error	check connections to motor
Er-3H*	reverse due to obstacle	check for obstacles in path
Er-4H*	thermal cutout error	Allow motor to cool
Er-5H*	anomaly in communication w/ remote devices	check Scs1 serial connections
Er-61	running off battery	--
Er-FH*	limit switch error	check limit switch connections

* H = 0,1,...,9,A,B,C,D,E,F

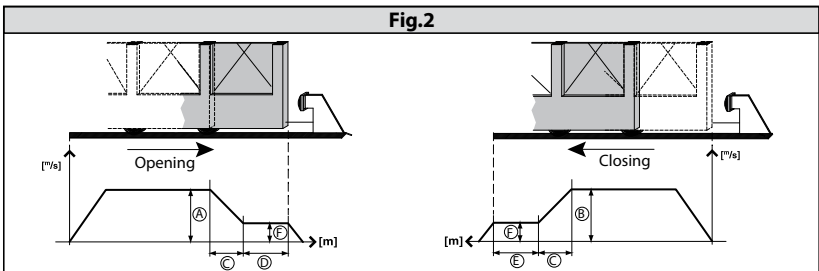

35.40

——— Set torque threshold

——— Maximum instantaneous motor torque

WARNING! Important safety instructions. Carefully read and comply with the Warnings booklet and Instruction booklet that come with the product as incorrect installation can cause injury to people and animals and damage to property. They contain important information regarding safety, installation, use and maintenance. Keep hold of instructions so that you can attach them to the technical file and keep them handy for future reference.

1) GENERAL SAFETY

WARNING! An incorrect installation or improper use of the product can cause damage to persons, animals or things.

- The units making up the machine and its installation must meet the requirements of the following European Directives: 2004/108/EEC, 2006/95/EEC, 2006/42/EEC, 89/106/EEC and later amendments. For all countries outside the EEC, it is advisable to comply with the above-mentioned standards, in addition to any national standards in force, to achieve a good level of safety.
- The Firm disclaims all responsibility resulting from improper use or any use other than that for which the product has been designed, as indicated herein, as well as for failure to apply Good Practice in the construction of entry systems (doors, gates, etc.) and for deformation that could occur during use.
- Make sure the stated temperature range is compatible with the site in which the automated system is due to be installed.
- Before performing installation, remove any cables or chains that are not needed and disable any equipment that is not required for installation purposes. Also check that the door/gate is in a good state of mechanical repair, is correctly balanced and opens and closes as it should do.
- Do not install the product in an explosive atmosphere.
- Disconnect the electricity supply before performing any work on the system. Also disconnect buffer batteries, if any are connected.
- Have the automated system's mains power supply fitted with a switch or omnipolar thermal-magnetic circuit breaker with a contact separation of at least 3.5 mm.
- Make sure that upline from the mains power supply there is a residual current circuit breaker that trips at 0.03A.
- Make sure the earth system has been installed correctly: earth all the metal parts belonging to the entry system (doors, gates, etc.) and all parts of the system featuring an earth terminal.
- Installation must be carried out using safety devices and controls that meet standard EN 12978.
- Apply all safety devices (photocells, safety edges, etc.) required to keep the area free of crushing, dragging and shearing hazards.
- The motor cannot be installed on panels incorporating doors (unless the motor can be activated when the door is open)
- If the automated device is installed at a height of less than 2.5 m or is accessible, the electrical and mechanical parts must be suitably protected.
- Any fixed controls must be installed within sight of the door but away from moving parts. Unless the control is key operated, it must be installed at a height of at least 1.5 m and in a place where it cannot be reached by the public
- Apply at least one warning light (flashing light) in a visible position, and also attach a Warning sign to the structure.
- If there are no instructions already, attach a label near the operating device, in a permanent fashion, with information on how to operate the manual release.
- Make sure that nothing can be crushed between the guided part and surrounding fixed parts during the door's operation
- Once installation is complete, make sure the motor has the right settings and that the safety and release systems are working properly.
- Only use original spare parts for any maintenance or repair work. The Firm disclaims all responsibility for the correct operation and safety of the automated system if parts from other manufacturers are used.
- Do not make any modifications to the automated system's components unless explicitly authorized by the Firm.
- Dispose of packaging materials (plastic, cardboard, polystyrene, etc.) in accordance with the provisions of the laws in force. Keep nylon bags and polystyrene out of reach of children.
- Anything which is not expressly provided for in the present instructions, is not allowed.
- Instruct the product user about the control systems provided and the manual opening operation in case of emergency.

Warning! For connection to the mains power supply, use a multicore cable with a cross-section of at least 4x1.5mm² of the kind provided for by the regulations mentioned above (by way of example, type H05 VV-F cable can be used with a cross-section of 4x1.5mm²). To connect auxiliary equipment, use wires with a cross-section of at least 0,75 mm².

Have an omnipolar circuit breaker installed with a contact separation of at least 3 mm and featuring overload protection, suitable for cutting the automated device off from the mains.

Only use pushbuttons with a capacity of 10A-250V or more.

The cables must be held in position using an extra fixing device in the proximity of the terminals, e.g. with cable clamps.

Also add more clips to the limit device wires, to the transformer primary or secondary wires, and to the wires connected to the printed circuit.

During installation, the power supply cable must be stripped in order for the earthing wire to be connected to the appropriate terminal, but the active

wires must be left as short as possible. The earthing wire must be the last to stretch in the case where the cable fixing device becomes loose.

⚠ WARNING: extremely low safety voltage cables must be physically separated from low voltage cables.

Access to the electrical compartment or to limit switches must be allowed to skilled personnel only.

⚠ Setting sensitivity incorrectly can result in damage to property and injury to people and animals.

Compliance with current safety rules with regard to people, animals and property must be assured at all times and, more specifically, measures must be taken to avoid risks of injury due to crushing, in the area where the pinion and rack mesh, and any other mechanical hazards. **All critical points must be protected by safety devices in accordance with the provisions of the regulations in force.**

CHECKING THE AUTOMATED DEVICE

Before the automated device is finally put into operation, perform the following checks meticulously:

- Make sure all components are fastened securely.
- Check the correct functioning of all safety devices (limit microswitches, photocells, sensitive edges etc.).
- Make sure that the anti-crush system stops the door within the limits provided for by the standards in force.
- Check the emergency operation control device.
- Check the opening and closing operations with the control devices in use.
- Check the standard and customised electronic functioning logic.

MAINTENANCE

WARNING: before opening the door, the spring must be unloaded (vertical boom). **WARNING:** Before carrying out any maintenance to the installation, disconnect the mains power supply. The following points need checking and maintenance:

- Photocell optics. Clean occasionally.
- Electric edge. Carry out a periodical manual check to ensure that the edge stops the bar in case of obstacles.
- Dismantle the gearmotor and replace the lubricating grease every two years.
- When any operational malfunction is found, and not resolved, disconnect the mains power supply and request the assistance of a specialised technician (installer). When the operator is out of order, activate the emergency release (see Fig.2), if necessary, so as to release the manual boom opening and closing operations.

SCRAPPING

Materials must be disposed of in conformity with the current regulations. In case of scrapping, the automation devices do not entail any particular risks or danger. In case of recovered materials, these should be sorted out by type (electrical components, copper, aluminium, plastic etc.).

DISMANTLING

When the automation system is disassembled to be reassembled on another site, proceed as follows:

- Disconnect the power supply and the entire electrical installation.
- Remove the actuator from its fixing base.
- Disassemble all the installation components.
- In the case where some of the components cannot be removed or are damaged, they must be replaced.

Correct controller operation is only ensured when the data contained in the present manual are observed. The Company is not to be held responsible for any damage resulting from failure to observe the installation standards and the instructions contained in the present manual. The descriptions and illustrations contained in the present manual are not binding. The Company reserves the right to make any alterations deemed appropriate for the technical, manufacturing and commercial improvement of the product, while leaving the essential product features unchanged, at any time and without undertaking to update the present publication.

INSTALLATION MANUAL

1) FOREWORD

The **ARES** actuator is highly versatile in terms of installation options due to the extremely low position of the pinion, the actuator's compact nature and the height and depth adjustment features it offers. The adjustable electronic torque limiter provides anti-crush safety. Manual emergency operation is extremely easy to perform using just a knob.

Stopping at end of travel is controlled by electromechanical microswitches.

The built-in control panel controls the start relays and safety devices (photocells, safety edge) each time before performing any operation.

2) TECHNICAL SPECIFICATIONS

MOTOR	
Power supply	single-phase 230V \pm 10%, 50Hz (*)
Power input	250 W (ARES 1500) 240 W (ARES 1000)
Pinion module	4mm (18 teeth) (ARES 1500/ARES 1000) 4mm (25 teeth) (ARES 1500V / ARES 1000 V)
Leaf speed	9 m/min (ARES 1500/ARES 1000) 12 m/min (ARES 1500V / ARES 1000V)
Max. leaf weight	1500 Kg (ARES 1500) 1000 Kg (ARES 1000) 750 Kg (ARES 1500V) 500 Kg (ARES 1000V)
Max. torque	35 Nm (ARES 1500) 30 Nm (ARES 1000)
Impact reaction	Electronic torque limiter
Lubrication	Lifetime greased
Manual operation	Knob-operated mechanical release
Type of use	intensive
Buffer batteries (optional extras)	Two 12V 1.2Ah batteries
Environmental conditions	from -15°C to +60°C
Protection rating	IP24
Noise level	<70dBA
Operator weight	7 kg
Dimensions	See Fig. K
CONTROL UNIT	
Accessories power supply	24V ~ (180 mA)
Fuses	Fig. G
Built-in Rolling-Code radio-receiver	frequency 433.92MHz
Setting of parameters and options	Universal handheld programmer/LCD display
N° of combinations	4 billion
Max. n° of remotes that can be memorized	63

(*) Special supply voltages to order.

Usable transmitter versions:

All ROLLING CODE transmitters compatible with



3) TUBE ARRANGEMENT Fig.A

Install the electrical system referring to the standards in force for electrical systems CEI 64-8, IEC 364, harmonization document HD 384 and other national standards.

4) PREPARATION FOR MOTOR MOUNTING FIG.B

- Make a hole in the ground to accommodate the concrete pad, with anchors embedded in the base plate for fastening the gearbox assembly, keeping to the distances featured in **FIG.B**.
- To keep the base plate in the right position during installation, it may be useful to weld two iron plates under the track to which the anchors can then be welded (**FIG.M**).

5) MOUNTING THE MOTOR FIG.C

6) MOUNTING DRIVE ACCESSORIES FIG.D-D1

7) RACK CENTRING WITH RESPECT TO PINION FIG.N-O1-P

⚠ DANGER - Welding must be performed by a competent person issued with the necessary personal protective equipment as prescribed by the safety rules in force FIG.O.

8) FASTENING LIMIT SWITCH BRACKETS FIG.E

9) STOPS FIG.Q

⚠ DANGER - The gate must be fitted with mechanical stops to halt its travel both when opening and closing, thus preventing the gate from coming off the top guide. Said stops must be fastened firmly to the ground, a few centimetres beyond the electric stop point.

10) MANUAL RELEASE (See USER GUIDE -FIG.2-).

Warning Do not JERK the gate open and closed, instead push it GENTLY to the end of its travel.

11) TERMINAL BOARD WIRING Fig. F-G

Once suitable electric cables have been run through the raceways and the automated device's various components have been fastened at the predetermined points, the next step is to connect them as directed and illustrated in the diagrams contained in the relevant instruction manuals. Connect the live, neutral and earth wire (compulsory). The mains cable must be clamped in the relevant cable gland (**FIG.R-ref.P1**), and the accessories' wires in the cable gland (**FIG.R-ref.P2**), while the earth wire with the yellow/green-coloured sheath must be connected in the relevant terminal (**FIG.R-ref.S**).

TERMINAL	DESCRIPTION
1-2	Motor connection.
3-4	24V transformer secondary windin (3-, 4+).
5-6	Closing limit switch SWC (5 Black common - 6 Red).
5-7	Opening limit switch SWO (5 Black common -7 Brown).
8-9	Flashing light 24V max. 25W.
10-11	Antenna (10 signal - 11 braiding). Use an antenna tuned to 433MHz. Use RG58 coax cable to connect the Antenna and Receiver. Metal bodies close to the antenna can interfere with radio reception. If the transmitter's range is limited, move the antenna to a more suitable position.
12-13	Accessories power supply: 24 V operation with mains power on. 24 V (12-,13+) operation with no mains power and optional buffer battery kit.
14-15	Free contact (NO). Gate Open Light SCA (24V max. 3W) or 2nd radio channel output (FIG.G-ref.1). This option can be set via the "logic menu".
16-17	Safety device power supply output (photocell transmitter and safety edge transmitter). N.B.: output active only during operating cycle. 24 V Vsafe operation with mains power on. 24 V (16-,17+) Vsafe operation with no mains power and optional buffer battery kit.
18	Safety device test input FAULT - PHOT (N.O.).
19-20	PEDESTRIAN control button (N.O.) Opens the gate by the distance set with the "Partial Opening" parameter
21-22	START/CLOSE control button (N.O.). This option can be set via the "logic menu". Start - operation according to 3/4-step logic Close - The command causes the leaf to close.
21-23	STOP input (N.C.) The command stops movement. If not used, leave jumper inserted.
21-24	PHOTOCELL input (N.C.) Operation according to photocell during opening logic. If not used, leave jumper inserted.
21-25	Safety edge input BAR (NC). The command reverses movement for 2 secs. If not used, leave jumper inserted.
21-26	OPEN control button (N.O.). Gate opened with this command.
27	Safety device test input FAULT - BAR
31-32	230V~ transformer primary winding.
33-34	Single-phase power supply 230V, 50-60Hz (33N - 34L).

12) SAFETY DEVICES

NOTE: ONLY USE RECEIVING SAFETY DEVICES WITH FREE CHANGEVER CONTACT.

12.1) TESTED DEVICES (FIG. U)

12.2) NON-TESTED DEVICES (FIG. H, U)

13) CALLING UP MENUS: FIG. 1

13.1) PARAMETERS MENU (P_{RR}-R_{FF}) (PARAMETERS TABLE "A")

13.2) LOGIC MENU (L_{oG}-I_c) (LOGIC TABLE "B")

13.3) RADIO MENU (R_{Rd}-I_o) (RADIO TABLE "C")

- IMPORTANT NOTE: THE FIRST TRANSMITTER MEMORIZED MUST BE IDENTIFIED BY ATTACHING THE KEY LABEL (MASTER).

In the event of manual programming, the first transmitter assigns the RECEIVER'S KEY CODE: this code is required to subsequently clone the radio transmitters. The Clonix built-in on-board receiver also has a number of important advanced features:

- Cloning of master transmitter (rolling code or fixed code).
- Cloning to replace transmitters already entered in receiver.
- Transmitter database management.
- Receiver community management.

To use these advanced features, refer to the universal handheld programmer's instructions and to the general receiver programming guide.

13.4) LANGUAGE MENU (LANGUAGE)

Used to set the programmer's language on the display.

13.5) DEFAULT MENU (DEFAULT)

Restores the controller's DEFAULT factory settings. Following this reset, you will need to run the AUTOSET function again.

13.6) AUTOSET MENU (AUTOSET)

- Launch an autose operation by going to the relevant menu on the panel.
- As soon as you press the OK button, the "....." message is displayed and the control unit commands the door to perform a full cycle (opening followed by closing), during which the minimum torque value required for the door to move is set automatically. The number of cycles required for the autose function can range from 1 to 3. During this stage, it is important to avoid breaking the photocells' beams and not to use the START and STOP commands or the display. Once this operation is complete, the control unit will have automatically set the optimum torque values. Check them and, where necessary, edit them as described in the programming section.

WARNING: Check that the force of impact measured at the points provided for by standard EN 12445 is lower than the value laid down by standard EN 12453.

Warning!! While the autose function is running, the obstacle detection function is not active. Consequently, the installer must monitor the automated system's movements and keep people and property out of range of the automated system.

14) CONNECTION WITH EXPANSION BOARDS AND UNIVERSAL HANDHELD PROGRAMMER (Fig.S)

Refer to specific manual.

15) SCS OPTIONAL MODULES

15.1) SERIAL CONNECTION VIA SCS1 CARD (Fig. U)

The control panel's special serial inputs and outputs (SCS1) make the centralized connection of a number of automated devices possible. That way, all the automated devices connected can be opened or closed with a single command. Connect all control panels using twisted pair cabling only, proceeding as shown in the diagram in Fig. U.

When using a telephone cable with more than one pair, it is essential to use wires from the same pair.

The length of the telephone cable between one unit and the next must not be greater than 250 m.

At this point, each control panel needs to be configured appropriately, starting by entering a MASTER control panel that will have control over all the others, which therefore have to be set as SLAVE units (see logic menu). Also set the Zone number (see parameters menu) in the range 0 to 127. The zone number allows you to create groups of automated devices, each of which answers to the Zone Master. Each zone can have only one Master: the Master of zone 0 also controls the Slaves of the other zones. **Warning:** the control panel set as the MASTER must be the first in the series.

15.2) Opposite sliding leaves (Fig. T)

By means of a serial connection, it is also possible to obtain centralised control of two opposite barriers/gates.

In this case, the Master M1 control panel will simultaneously manage closing and opening for the Slave M2 control panel.

SETTING REQUIRED FOR OPERATION:

- MASTER board: ZONE=128, PARSER=ON
- SLAVE board: ZONE=128, PARSER=OFF

WIRING REQUIRED FOR OPERATION:

- The MASTER and SLAVE control units are interconnected through the 4 wires (RX/TX) for the SCS1 interface boards;
- All the activation controls, as well as the remote controls must refer to the MASTER board;
- All the photocells (checked or unchecked) must be connected to the MASTER control panel;
- The safety edges (checked or unchecked) of the MASTER leaf must be connected to the MASTER control unit;
- The safety edges (checked or unchecked) of the SLAVE leaf must be connected to the SLAVE control unit.

15.3) EXPANDING OUTPUTS FOR SAFETY DEVICE TESTING VIA SCS-MA BOARD (FIG. V)

When testing more than 2 devices (Ref. 4, 5, D, E Fig. V), the SCS-MA auxiliary board must be used.

15.4) Interface with WIEGAND systems via SCS-WIE module.

Refer to the SCS-WIE module's instructions.

13.1) TABLE A: PARAMETERS MENU (PARAMETERS)

Parameter	min.	max.	default	personal	Definition	Description
t <small>C</small> R	0	120	40		Automatic Closing Time	Automatic closing time [s]
S <small>L</small> OW S <small>P</small> E <small>E</small> D	15	50	15		Slow-down speed	Slow-down speed [%] (Fig.2 Rif. F) Set the speed the gate must reach slowing down, in percentage to the actuator's maximum speed. WARNING: should this parameter be edited, it will be followed by a complete opening/closing cycle for setting purposes (reported by the message "SET" appearing on the display), during which obstacle detection is not enabled.
OP <small>T</small> S <small>L</small> OW	1	99	75		Opening motor torque	Opening torque [%] Sets sensitivity to obstacles during opening (1=max., 99=min.) The autose feature sets this parameter automatically to a value of 10%. The user can edit this parameter based on how sensitive the door needs to be to obstacles.
CL <small>S</small> E S <small>L</small> OW	1	99	75		Closing motor torque	Closing torque [%] Sets sensitivity to obstacles during closing (1=max., 99=min.) The autose feature sets this parameter automatically to a value of 10%. The user can edit this parameter based on how sensitive the door needs to be to obstacles.
OP S <small>P</small> E <small>E</small> D	15	99	99		Speed during opening	Running speed during opening [%] (Fig. 2 Rif. A) Sets the running speed that the door must reach during opening, as a percentage of the maximum speed the actuator can reach. WARNING: should this parameter be edited, it will be followed by a complete opening/closing cycle for setting purposes (reported by the message "SET" appearing on the display), during which obstacle detection is not enabled.
CL S <small>P</small> E <small>E</small> D	15	99	99		Speed during closing	Running speed during closing [%] (Fig. 2 Rif. B) Sets the running speed that the door must reach during closing, as a percentage of the maximum speed the actuator can reach. The autose feature sets this parameter automatically. WARNING: should this parameter be edited, it will be followed by a complete opening/closing cycle for setting purposes (reported by the message SET appearing on the display), during which obstacle detection is not enabled.
P <small>AR</small> T <small>I</small> AL I <small>RL</small> O <small>P</small> E <small>N</small> I <small>N</small> G	10	99	40		Partial opening	Partial opening [%] Adjusts partial opening percentage compared to total opening in "Partial open" mode.
Z <small>ONE</small>	0	128	0		Zone	Zone [] Sets the zone number of the door included in the serial connection for commands via central controllers. Zone 128: Serial connection for opposite Sliding Leaves.
d <small>IS</small> T <small>E</small> d <small>E</small> C <small>E</small> L (special par 18*)	0	50	0		Slow-down distance	Slow-down distance [%] (Fig.2 Rif. C) Set the distance the gate needs to go from from high to low speed in percentage to total travel. WARNING: should this parameter be edited, it will be followed by a complete opening/closing cycle for setting purposes (reported by the message "SET" appearing on the display), during which obstacle detection is not enabled.
OP <small>D</small> I <small>S</small> T <small>E</small> d <small>E</small> C <small>E</small> L (special par 19*)	5	50	10		Opening deceleration space	Opening deceleration space [%] (Fig.2 Rif. D) Set the opening slow-down distance in percentage to total travel. This distance is covered at low speed. WARNING: should this parameter be edited, it will be followed by a complete opening/closing cycle for setting purposes (reported by the message "SET" appearing on the display), during which obstacle detection is not enabled.
CL <small>D</small> I <small>S</small> T <small>E</small> d <small>E</small> C <small>E</small> L (special par 20*)	5	50	10		Closing deceleration space	Closing slow-down distance [%] (Fig.2 Rif. E) Set the closing slow-down distance in percentage to total travel. This distance is covered at low speed. WARNING: should this parameter be edited, it will be followed by a complete opening/closing cycle for setting purposes (reported by the message "SET" appearing on the display), during which obstacle detection is not enabled.

*=Refer for universal handheld programmer.

INSTALLATION MANUAL

13.2) TABLE "B" - LOGIC MENU - (L o U l c)

Logic	Default	Definition	Cross out setting used	Description																	
t c R	OFF	Automatic Closing Time	ON	Activates automatic closing																	
			OFF	Excludes automatic closing																	
i b l o P E n	OFF	Opening Impulse lock	ON	The Start impulse has no effect during the opening phase.																	
			OFF	The Start impulse becomes effective during the opening phase.																	
i b l t c R	OFF	Impulse lock TCA	ON	The Start impulse has no effect during the TCA dwell period.																	
			OFF	The Start impulse becomes effective during the TCA dwell period.																	
3 S t E P	OFF	3 step	ON	Switches to 3-step logic.																	
			OFF	Switches to 4-step logic.																	
<i>A start impulse has the following effects:</i>																					
				<table border="1" style="width: 100%; text-align: center;"> <thead> <tr> <th></th> <th>3 steps</th> <th>4 steps</th> </tr> </thead> <tbody> <tr> <td>closed</td> <td rowspan="2">opens</td> <td>opens</td> </tr> <tr> <td>on closing</td> <td>stop</td> </tr> <tr> <td>open</td> <td>closes</td> <td>closes</td> </tr> <tr> <td>on opening</td> <td>stop + TCA</td> <td>stop + TCA</td> </tr> <tr> <td>after stop</td> <td>opens</td> <td>opens</td> </tr> </tbody> </table>		3 steps	4 steps	closed	opens	opens	on closing	stop	open	closes	closes	on opening	stop + TCA	stop + TCA	after stop	opens	opens
	3 steps	4 steps																			
closed	opens	opens																			
on closing		stop																			
open	closes	closes																			
on opening	stop + TCA	stop + TCA																			
after stop	opens	opens																			
P r E A L	OFF	Pre-alarm	ON	The flashing light comes on approx. 3 seconds before the motors start.																	
			OFF	The flashing light comes on at the same time as the motors start.																	
h o l d t o r u n	OFF	Deadman	ON	Hold-to-run operation: the manoeuvre continues as long as the OPEN and CLOSE control keys are kept pressed. The radio transmitter cannot be used.																	
			OFF	Normal impulse operation.																	
P h o t o c. o P E n	OFF	Photocells during opening	ON	When beam is broken, operation of the photocell is switched off during opening. During closing, movement is reversed immediately.																	
			OFF	When beam is broken, photocells are active during both opening and closing. When beam is broken during closing, movement is reversed only once the photocell is cleared.																	
t E S t P h o t	OFF	Photocell test	ON	Switches photocell testing on																	
			OFF	Switches photocell testing off If disabled (OFF), it inhibits the photocell testing function, enabling connection of devices not equipped with supplementary test contacts.																	
t E S t b A R	OFF	Safety edge testing	ON	Switches safety edge testing on.																	
			OFF	Switches safety edge testing off If disabled (OFF), it inhibits the safety edge testing function, enabling connection of devices not equipped with supplementary test contacts.																	
M A S T E R	OFF	Master/slave	ON	Control panel is set up as the Master unit in a centralized serial connection system.																	
			OFF	Control panel is set up as a Slave unit in a centralized serial connection system.																	
F I X E d c o d E	OFF	Fixed code	ON	Receiver is configured for operation in fixed-code mode.																	
			OFF	Receiver is configured for operation in rolling-code mode.																	
r R d i a P r o G	ON	Remote control programming	ON	Enables wireless memorizing of transmitters: 1- Press in sequence the hidden key (P1) and normal key (T1-T2-T3-T4) of a transmitter that has already been memorized in standard mode via the radio menu. 2- Press within 10 secs. the hidden key (P1) and normal key (T1-T2-T3-T4) of a transmitter to be memorized. IMPORTANT: Enables the automatic addition of new transmitters, clones and replays. The receiver exits programming mode after 10 secs.: you can use this time to enter other new transmitters. This mode does not require access to the control panel.																	
			OFF	Disables wireless memorizing of transmitters. Transmitters are memorized only using the relevant Radio menu. IMPORTANT: Disables the automatic addition of new transmitters, clones and replays.																	
S c R 2 c h	OFF	Gate open light or 2nd radio channel	ON	The output between terminals 14-15 is set as Gate open light: in this case, the 2nd radio channel controls pedestrian opening.																	
			OFF	The output between terminals 14-15 is set as 2nd radio channel.																	
S t A R t - c l o S E	OFF	START - CLOSE setting	ON	Input between terminals 21-22 works as CLOSE.																	
			OFF	Input between terminals 21-22 works as START.																	
c h A n G E M o t.	OFF	Reversing motion	ON	Change this parameter if the opening direction needs to be changed																	
			OFF	Standard operating mode.																	
I c E (special dip 2*)	OFF	ICE	ON	The controller automatically adjusts the Amperostop safety trip threshold. Check that the force of impact measured at the points provided for by standard EN 12445 is lower than the value laid down by standard EN 12453. If in doubt, use auxiliary safety devices. This feature is useful when dealing with installations running at low temperatures. WARNING: once this feature has been activated, you will need to perform an autoset opening and closing cycle.																	
			OFF	The Amperostop safety trip threshold stays at the same set value.																	

*=Refer for universal handheld programmer.

13.3) TABLE C: RADIO MENU (r R d i a)

Logic	Description
R d d S t A R t	Add Start Key associates the desired key with the Start command.
R d d 2 c h	Add 2ch Key associates the desired key with the 2nd radio channel command.
E r A S E 5 4	Erase List WARNING! Erases all memorized remote controls from the receiver's memory.
c o d r H	Read receiver code Displays receiver code required for cloning remote controls.
W L K	ON = Enables remote programming of cards via a previously memorized W LINK transmitter. It remains enabled for 3 minutes from the time the W LINK remote control is last pressed. OFF = W LINK programming disabled.

Fig. 2

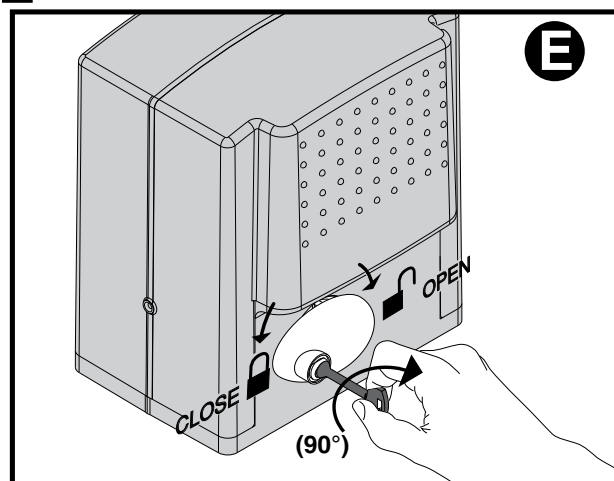
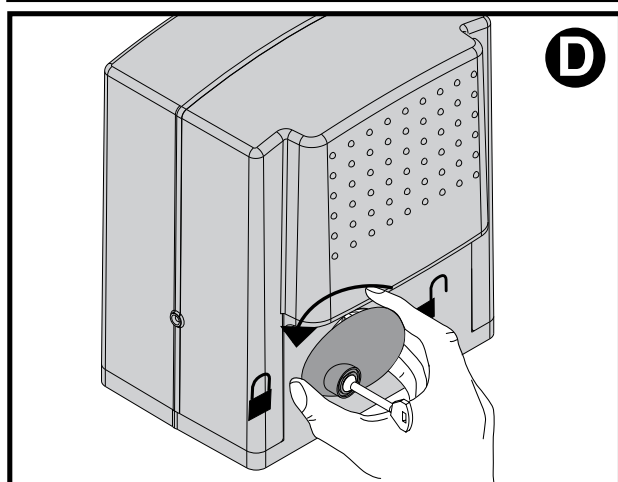
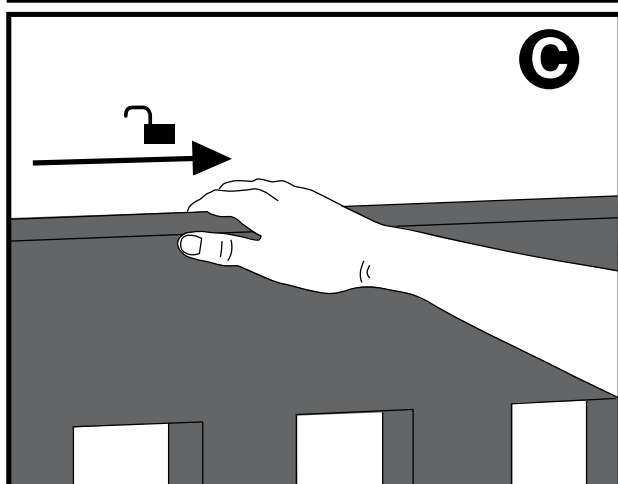
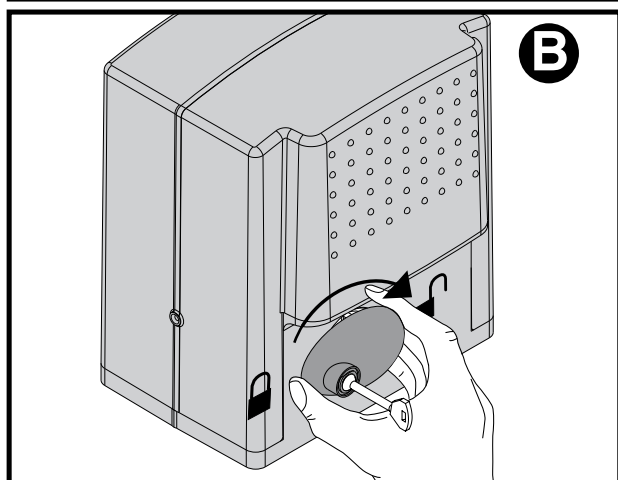
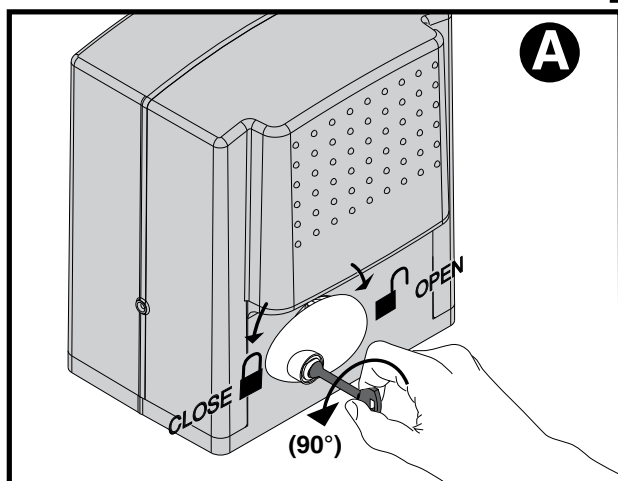

MANUALE D'USO (I)

Nel ringraziarVi per la preferenza accordata a questo prodotto, la Ditta è certa che da esso otterrete le prestazioni necessarie al Vostro uso. Questo prodotto risponde alle norme riconosciute della tecnica e della disposizioni relative alla sicurezza. Confermiamo che è conforme alle seguenti direttive europee: 2004/108/CEE, 2006/95/CEE, 2006/42/CEE, 99/05/CEE (e loro modifiche successive).

1) SICUREZZA GENERALE

ATTENZIONE Importanti istruzioni di sicurezza. Leggere e seguire attentamente l'opuscolo Avvertenze ed il Libretto istruzioni che accompagnano il prodotto poiché un uso improprio può causare danni a persone, animali o cose. Conservare le istruzioni per consultazioni future.

Questo prodotto è stato progettato e costruito esclusivamente per l'utilizzo indicato in questa documentazione. Usi non indicati potrebbero essere fonte di danni al prodotto e fonte di pericolo.

- La Ditta declina qualsiasi responsabilità derivante da un uso improprio o diverso da quello per cui è destinato ed indicato nella presente documentazione nonché dall'inosservanza della Buona Tecnica nella costruzione delle chiusure (porte, cancelli, ecc.) e dalle deformazioni che potrebbero verificarsi durante l'uso.

L'automazione, se installata ed utilizzata correttamente, soddisfa il grado di sicurezza richiesto.

Tuttavia è opportuno osservare alcune regole di comportamento per evitare inconvenienti accidentali:

- Tenere bambini, persone e cose fuori dal raggio d'azione dell'automazione, in particolare durante il funzionamento.
- Quest' applicazione non è destinata all'uso da parte di persone (inclusi i bambini) con ridotte capacità mentali, fisiche e sensoriali, o persone che mancano di conoscenze adeguate, a meno che non siano sotto supervisione o abbiano ricevuto istruzioni d'uso da persone responsabili della loro sicurezza.
- I bambini devono essere controllati affinché non giochino con l'applicazione. Non lasciare radiocomandi o altri dispositivi di comando alla portata dei bambini onde evitare azionamenti involontari.
- L'attivazione dello sblocco manuale potrebbe causare movimenti incontrollati della porta se in presenza di guasti meccanici o di condizioni di squilibrio.
- Non contrastare volontariamente il movimento dell'anta e non tentare di aprire manualmente la porta se non è stato sbloccato l'attuatore con l'apposita manopola di sblocco
- Controllare spesso l'impianto, in particolare cavi, molle o supporti per scoprire eventuali sbilanciamenti e segni di usura o danni.
- Per ogni operazione di pulizia esterna o altra manutenzione, togliere l'alimentazione di rete
- Tenere pulite le ottiche delle fotocellule ed i dispositivi di segnalazione luminosa. Controllare che rami ed arbusti non disturbino i dispositivi di sicurezza (fotocellule).
- Non utilizzare l'automatismo se necessita di interventi di riparazione. In caso di malfunzionamento, togliere l'alimentazione, attivare lo sblocco di emergenza per consentire l'accesso e richiedere l'intervento di un tecnico qualificato (installatore professionale).
- Per qualsiasi intervento diretto all'automazione, avvalersi di personale qualificato (installatore professionale).
- Annualmente far controllare l'automazione da personale qualificato.
- Tutto quello che non è espressamente previsto in queste istruzioni, non è permesso.
- Il buon funzionamento dell'operatore è garantito solo se vengono rispettati i dati riportati in questo manuale. La ditta non risponde dei danni causati dall'inosservanza delle norme di installazione e delle indicazioni riportate in questo manuale.
- Le descrizioni e le illustrazioni del presente manuale non sono impegnative. Lasciando inalterate le caratteristiche essenziali del prodotto, la Ditta si riserva di apportare in qualunque momento le modifiche che essa ritiene convenienti per migliorare tecnicamente, costruttivamente e commercialmente il prodotto, senza impegnarsi ad aggiornare la presente pubblicazione.



USER'S MANUAL (GB)

Thank you for choosing this product. The Firm is confident that its performance will meet your operating needs. This product meets recognized technical standards and complies with safety provisions. We hereby confirm that it is in conformity with the following European directives: 2004/108/EEC, 2006/95/EEC, 2006/42/EEC, 99/05/EEC (and later amendments).

1) GENERAL SAFETY

WARNING Important safety instructions. Carefully read and comply with the Warnings booklet and Instruction booklet that come with the product as improper use can cause injury to people and animals and damage to property. Keep hold of instructions for future reference. This product has been designed and built solely for the purpose indicated herein. Uses not contemplated herein might result in the product being damaged and could be a source of danger

- The Firm disclaims all responsibility resulting from improper use or any use other than that for which the product has been designed, as indicated herein, as well as for failure to apply Good Practice in the construction of entry systems (doors, gates, etc.) and for deformation that could occur during use.

If installed and used correctly, the automated system will meet the required level of safety. Nonetheless, it is advisable to observe certain rules of behaviour so that accidental problems can be avoided:

- Keep adults, children and property out of range of the automated system, especially while it is operating.
- This application is not meant for use by people (including children) with impaired mental, physical or sensory capacities, or people who do not have suitable knowledge, unless they are supervised or have been instructed by people who are responsible for their safety.
- Children must be supervised to ensure they do not play with the application. Keep remote controls or other control devices out of reach of children in order to avoid the automated system being operated inadvertently.
- The manual release's activation could result in uncontrolled door movements if there are mechanical faults or loss of balance.
- Do not deliberately hinder the door's movement and do not attempt to open the door manually unless the actuator has been released with the relevant release knob.
- Check the system frequently, especially cables, springs or supports, to detect any loss of balance and signs of wear or damage.
- When cleaning the outside or performing other maintenance work, always cut off mains power.
- Keep the photocells' optics and illuminating indicator devices clean. Check that no branches or shrubs interfere with the safety devices (photocells).
- Do not use the automated system if it is in need of repair. In the event of a malfunction, cut off the power, activate the emergency release to allow access and call in qualified technical personnel (professional installer).
- If the automated system requires work of any kind, employ the services of qualified personnel (professional installer).
- Have the automated system checked by qualified personnel once a year.
- Anything that is not explicitly provided for in these instructions is not allowed.
- The operator's proper operation can only be guaranteed if the information given herein is complied with. The Firm shall not be answerable for damage caused by failure to comply with the installation rules and instructions featured herein.
- Descriptions and illustrations herein are not binding. While we will not alter the product's essential features, the Firm reserves the right, at any time, to make those changes deemed opportune to improve the product from a technical, design or commercial point of view, and will not be required to update this publication accordingly.

MANUEL D'UTILISATION (F)

Nous vous remercions d'avoir choisi ce produit qui, nous n'en doutons pas, saura vous garantir les performances attendues. Ce produit est conforme aux normes techniques et aux prescriptions de sécurité établies. Nous confirmons qu'il est conforme aux directives européennes suivantes: 2004/108/CEE, 2006/95/CEE, 2006/42/CEE (et leurs modifications successives).

1) SÉCURITÉ GÉNÉRALE

ATTENTION Instructions de sécurité importantes. Veuillez lire et suivre attentivement la brochure Avertissement et le Manuel d'instructions fournis avec le produit sachant qu'un usage incorrect peut provoquer des préjudices aux personnes, aux animaux ou aux choses. Rangez soigneusement les instructions afin de pouvoir les consulter par la suite.

Ce produit a été conçu et réalisé exclusivement pour l'usage indiqué dans cette documentation. Tout autre usage risque d'endommager l'appareil et d'être à l'origine de dangers.

- L'entreprise décline toute responsabilité dérivant d'un usage incorrect ou différent de celui prévu et indiqué dans la présente documentation, de l'inobservation de la bonne technique dans la construction des fermetures (portes, portails, etc.) et des déformations pouvant apparaître à l'usage.

Si l'automatisation est montée et utilisée correctement, elle est conforme au degré de sécurité prescrit. Il est cependant nécessaire de respecter certaines règles de comportement pour éviter tout inconvénient accidentel:

- L'entreprise décline toute responsabilité dérivant d'un usage incorrect ou différent de celui prévu et indiqué dans la présente documentation, de l'inobservation de la bonne technique dans la construction des fermetures (portes, portails, etc.) et des déformations pouvant apparaître à l'usage.
- Si l'automatisation est montée et utilisée correctement, elle est conforme au degré de sécurité prescrit. Il est cependant nécessaire de respecter certaines règles de comportement pour éviter tout inconvénient accidentel.
- Tenez les enfants, les personnes et les objets à l'écart du rayon d'action de l'automatisation, en particulier pendant son fonctionnement.

- Cette application n'est pas destinée à être utilisée par des personnes (y compris les enfants) ayant des capacités mentales, physiques et sensorielles réduites, ni par des personnes dépourvues des connaissances nécessaires, à moins d'agir sous la supervision de personnes responsables de leur sécurité ou d'avoir reçues les instructions nécessaires de ces mêmes personnes.
- Les enfants doivent être surveillés car ils ne doivent en aucun cas jouer avec l'application. Rangez les radiocommandes ou les autres dispositifs de commande hors de portée des enfants afin d'éviter tout actionnement involontaire de l'automatisation.
- L'activation du déverrouillage manuel risque de provoquer des mouvements incontrôlés de la porte en présence de pannes mécaniques ou de conditions de déséquilibre.
- Ne vous opposez pas volontairement au mouvement du vantail et ne tentez pas d'ouvrir la porte à la main si le déclencheur n'est pas déverrouillé avec le levier de déverrouillage prévu à cet effet.
- Contrôlez souvent l'installation, en particulier au niveau des câbles, des ressorts ou des supports pour découvrir les éventuels déséquilibres et signes d'usure ou de dommage.
- Mettez hors tension l'application avant d'accomplir les opérations de nettoyage extérieur ou toute autre opération d'entretien.
- Veillez à la propreté des systèmes optiques des photocellules et des lampes de signalisation. Veillez à ce que les dispositifs de sécurité ne soient pas dérangés par des branches ou des arbustes (photocellules).
- N'utilisez pas l'automatisation si elle doit être réparée. En cas de mauvais fonctionnement, mettez hors tension, activez le déverrouillage d'urgence pour autoriser l'accès et demandez l'intervention d'un technicien qualifié (monteur professionnel).
- Faites toujours appel à du personnel qualifié (monteur professionnel) si vous devez intervenir directement sur l'automatisation.
- Faites contrôler une fois par an l'automatisation par du personnel qualifié.
- Tout ce qui n'est pas expressément prévu dans ces instructions, est interdit.
- Le bon fonctionnement de l'actionneur n'est garanti que si les instructions données dans ce manuel sont respectées. L'entreprise ne répond pas des dommages provoqués par l'inobservation des normes d'installation et des indications données dans ce manuel.
- Les descriptions et les illustrations du présent manuel ne sont pas contraignantes. Sans modifier les caractéristiques essentielles de l'appareil, l'entreprise se réserve le droit d'apporter à tout moment les modifications qu'elle jugera opportunes pour améliorer le produit du point de vue technique, commercial et de sa construction, sans s'engager à mettre à jour la présente publication.

BEDIENUNGSANLEITUNG (D)

Wir danken Ihnen dafür, dass Sie diesem Produkt den Vorzug gegeben haben, und sind sicher, dass Sie mit ihm die für Ihre Anwendung erforderlichen Leistungen erzielen werden. Dieses Produkt entspricht den anerkannten technischen Normen sowie den Sicherheitsbestimmungen. Es entspricht den folgenden EU-Richtlinien: 2004/108, 2006/95, 2006/42 (sowie nachfolgende Abänderungen).

1) ALLGEMEINE SICHERHEIT

ACHTUNG Wichtige Hinweise zur Sicherheit. Bitte lesen und befolgen Sie aufmerksam die Hinweise sowie die Bedienungsanleitung, die das Produkt begleiten, denn eine falsche Benutzung des Produkts kann zu Verletzungen von Menschen und Tieren sowie zu Sachschäden führen. Bitte bewahren Sie die Anweisungen für zukünftige Konsultationen auf.

Dieses Produkt wurde ausschließlich für die in der vorliegenden Dokumentation angegebene Verwendung konzipiert und gefertigt. Nicht angegebene Verwendungsweisen können zu Schäden und Gefahren führen.

- Die Firma lehnt jegliche Haftung für Schäden ab, sind zurückzuführen sind auf eine unsachgemäße Benutzung, die von der in der vorliegenden Dokumentation verschieden ist, auf die Nichtbeachtung des Prinzips der sachgerechten Ausführung bei den Türen, Toren usw. oder Verformungen, die während der Benutzung auftreten können.

Bei ordnungsgemäßer Installation und Benutzung erfüllt die Automatisierung den geforderten Sicherheitsgrad. Dennoch sollte einige Verhaltensregeln beachtet werden, um Zwischenfälle zu vermeiden:

- Halten Sie Kinder, Personen und Sachen aus dem Wirkungsbereich der Automatisierung fern, vor allem während des Betriebs.
- Diese Anwendung ist nicht für die Benutzung durch Personen (einschließlich Kinder) mit eingeschränkten geistigen, körperlichen oder sensorischen Fähigkeiten bestimmt, oder aber durch Personen, die nicht über die erforderlichen Kenntnisse verfügen, es sein denn unter Überwachung oder nach Einweisung in die Benutzung durch die für ihre Sicherheit verantwortlichen Personen.
- Es muss sichergestellt werden, dass Kinder nicht mit der Automatisierung spielen. Halten Sie die Funkfernbedienung oder sonstige Steuerungsvorrichtungen von Kindern fern, um unbeabsichtigte Betätigungen der Automatisierung zu vermeiden. Die Aktivierung der manuellen Entsperrung könnte bei mechanischen Defekten oder Ungleichgewichtssituationen zu unkontrollierten Bewegungen der Tür führen.
- Halten Sie die Bewegung der Tür nicht absichtlich auf und versuchen Sie nicht, die Tür von Hand zu öffnen, wenn der Trieb nicht mit dem entsprechenden Entsperrhebel entsperrt worden ist.
- Kontrollieren Sie regelmäßig die Anlage und vor allem die Seile, die Federn und die Halterungen, um eventuelle Anzeichen von Ungleichgewicht oder Abnutzung festzustellen.
- Unterbrechen Sie vor allen externen Reinigungsarbeiten oder sonstigen Wartungsarbeiten die Stromversorgung.
- Halten Sie die Linsen der Fotozellen und die Anzeigevorrichtungen sauber. Stellen Sie sicher, dass die Sicherheitsvorrichtungen (Fotozellen) nicht durch Zweige oder Sträucher beeinträchtigt werden.
- Benutzen Sie die Automatisierung nicht, falls sie Reparatureingriffe erforderlich macht.